

UAF42

UNIVERSAL ACTIVE FILTER

FEATURES

- VERSATILE—
LOW-PASS, HIGH-PASS
BAND-PASS, BAND-REJECT
- SIMPLE DESIGN PROCEDURE
- ACCURATE FREQUENCY AND Q —
INCLUDES ON CHIP 1000pF $\pm 0.5\%$
CAPACITORS

APPLICATIONS

- TEST EQUIPMENT
- COMMUNICATIONS EQUIPMENT
- MEDICAL INSTRUMENTATION
- DATA ACQUISITION SYSTEMS
- MONOLITHIC REPLACEMENT FOR UAF41

DESCRIPTION

The UAF42 is a universal active filter which can be configured for a wide range of low-pass, high-pass, and band-pass filters. It uses a classical state-variable analog architecture with an inverting amplifier and two integrators. The integrators include on-chip 1000pF capacitors trimmed to 0.5%. This solves one of the most difficult problems of active filter design—obtaining tight tolerance, low-loss capacitors.

A DOS-compatible filter design program allows easy implementation of many filter types such as Butterworth, Bessel, and Chebyshev. A fourth, uncommitted FET-input op amp (identical to the other

three) can be used to form additional stages, or for special filters such as band-reject and Inverse Chebyshev.

The classical topology of the UAF42 forms a time-continuous filter, free from the anomalies and switching noise associated with switched-capacitor filter types.

The UAF42 is available in 14-pin plastic DIP and ceramic packages, and SOL-16 surface-mount packages, specified for the -25°C to $+85^{\circ}\text{C}$ temperature range.

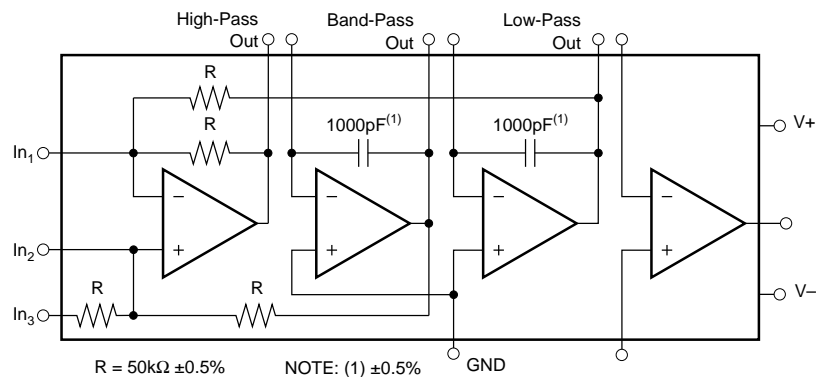

International Airport Industrial Park • Mailing Address: PO Box 11400 • Tucson, AZ 85734 • Street Address: 6730 S. Tucson Blvd. • Tucson, AZ 85706
Tel: (520) 746-1111 • Twx: 910-952-1111 • Cable: BBRCORP • Telex: 066-6491 • FAX: (520) 889-1510 • Immediate Product Info: (800) 548-6132

SPECIFICATIONS

ELECTRICAL

At $T_A = +25^\circ\text{C}$, $V_S = \pm 15\text{V}$, unless otherwise noted.

PARAMETER	CONDITIONS	UAF42AP, AU			UAF42AG			UNITS
		MIN	TYP	MAX	MIN	TYP	MAX	
FILTER PERFORMANCE								
Frequency Range, f_n	$f = 1\text{kHz}$		0 to 100			*		kHz
Frequency Accuracy vs Temperature			0.01	1		*	2	%
Maximum Q			400			*		—
Maximum (Q • Frequency) Product			500			*		kHz
Q vs Temperature	$(f_o \cdot Q) < 10^4$		0.01			*		%/°C
	$(f_o \cdot Q) < 10^5$		0.025			*		%/°C
Q Repeatability	$(f_o \cdot Q) < 10^5$		2			*		%
Offset Voltage, Low-Pass Output				±5			*	mV
Resistor Accuracy			0.5	1%		*	*	%
OFFSET VOLTAGE⁽¹⁾								
Input Offset Voltage vs Temperature			±0.5	±5		*	*	mV
vs Power Supply	$V_S = \pm 6$ to $\pm 18\text{V}$	80	±3		*	*		μV/°C
			96					dB
INPUT BIAS CURRENT⁽¹⁾								
Input Bias Current	$V_{CM} = 0\text{V}$		10	50		*	*	pA
Input Offset Current	$V_{CM} = 0\text{V}$		5			*		pA
NOISE								
Input Voltage Noise								
Noise Density: $f = 10\text{Hz}$			25			*		nV/√Hz
$f = 10\text{kHz}$			10			*		nV/√Hz
Voltage Noise: BW = 0.1 to 10Hz			2			*		μVp-p
Input Bias Current Noise								
Noise Density: $f = 10\text{kHz}$			2			*		fA/√Hz
INPUT VOLTAGE RANGE⁽¹⁾								
Common-Mode Input Range	$V_{CM} = \pm 10\text{V}$	80	±11.5		*	*		V
Common-Mode Rejection			96			*		dB
INPUT IMPEDANCE⁽¹⁾								
Differential			$10^{13} \parallel 2$			*		Ω pF
Common-Mode			$10^{13} \parallel 6$			*		Ω pF
OPEN-LOOP GAIN⁽¹⁾								
Open-Loop Voltage Gain	$V_O = \pm 10\text{V}$, $R_L = 2\text{k}\Omega$	90	126		*	*		dB
FREQUENCY RESPONSE⁽¹⁾								
Slew Rate			10			*		V/μs
Gain-Bandwidth Product	$G = +1$		4			*		MHz
Total Harmonic Distortion	$G = +1$, $f = 1\text{kHz}$		0.0004			*		%
OUTPUT⁽¹⁾								
Voltage Output	$R_L = 2\text{k}\Omega$	±11	±11.5		*	*		V
Short Circuit Current			±25			*		mA
POWER SUPPLY								
Specified Operating Voltage			±15	±18	*	*	*	V
Operating Voltage Range		±6		±7		*	*	V
Current			±6			*	*	mA
TEMPERATURE RANGE								
Specification		-25		+85	*		*	°C
Operating		-25		+85	-55		+125	°C
Storage		-40		+125	-65		+150	°C
Thermal Resistance, θ_{JA}			100			*		°C/W

* Same as specification for UAF42AP.

NOTES: (1) Specifications apply to uncommitted op amp, A_4 . The three op amps forming the filter are identical to A_4 but are tested as a complete filter.

The information provided herein is believed to be reliable; however, BURR-BROWN assumes no responsibility for inaccuracies or omissions. BURR-BROWN assumes no responsibility for the use of this information, and all use of such information shall be entirely at the user's own risk. Prices and specifications are subject to change without notice. No patent rights or licenses to any of the circuits described herein are implied or granted to any third party. BURR-BROWN does not authorize or warrant any BURR-BROWN product for use in life support devices and/or systems.

DICE INFORMATION

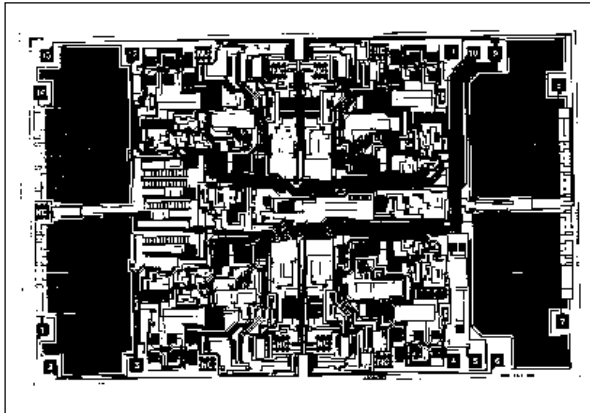

UAF42 DIE TOPOGRAPHY

PAD	FUNCTION	PAD	FUNCTION
1	Low Pass V_O	7	Bandpass V_O
2	V_{IN3}	8	Frequency Adj ₁
3	V_{IN2}	9	V^-
4	Aux. Op Amp, +In	10	V^+
5	Aux. Op Amp, -In	11	Ground
6	Aux. Op Amp, V_O	12	V_{IN1}
		13	High-Pass V_O
		14	Frequency Adj ₂

NC: No Connection.

Substrate Bias: Electrically connected to V^- supply.

MECHANICAL INFORMATION

	MILS (0.001")	MILLIMETERS
Die Size	205 x 130 ±5	5.21 x 3.30 ±0.13
Die Thickness	20 ±3	0.51 ±0.08
Min. Pad Size	4 x 4	0.10 x 0.10
Backing		Gold

PIN CONFIGURATION

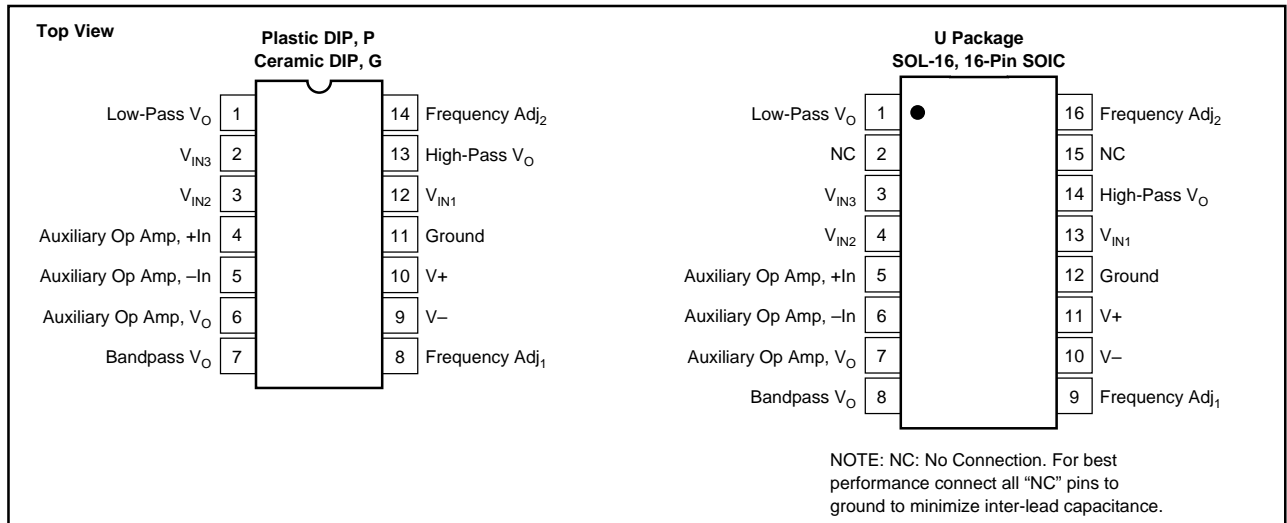

ABSOLUTE MAXIMUM RATINGS

Power Supply Voltage	±18V
Input Voltage	$\pm V_S \pm 0.7V$
Output Short Circuit	Continuous
Operating Temperature:	
Plastic DIP, P; SOIC, U	-40°C to +85°C
Ceramic DIP, G	-55°C to +125°C
Storage Temperature:	
Plastic DIP, P; SOIC, U	-40°C to +125°C
Ceramic DIP, G	-65°C to +150°C
Junction Temperature:	
Plastic DIP, P; SOIC, U	+125°C
Ceramic DIP, G	+150°C
Lead Temperature (soldering, 10s)	+300°C

ORDERING INFORMATION

MODEL	PACKAGE	TEMPERATURE RANGE
UAF42AP	Plastic 14-pin DIP	-25°C to +85°C
UAF42AG	Ceramic 14-pin DIP	-25°C to +85°C
UAF42AU	SOL-16	-25°C to +85°C

PACKAGING INFORMATION

MODEL	PACKAGE	PACKAGE DRAWING NUMBER (1)
UAF42AP	Plastic 14-pin DIP	010
UAF42AG	Ceramic 14-pin DIP	163
UAF42AU	SOL-16	211

NOTE: (1) For detailed drawing and dimension table, please see end of data sheet, or Appendix D of Burr-Brown IC Data Book.

APPLICATIONS INFORMATION

The UAF42 is a monolithic implementation of the proven state-variable analog filter topology. Pin-compatible with the popular UAF41 Analog Filter, it provides several improvements.

Slew Rate of the UAF42 has been increased to 10V/μs versus 1.6V/μs for the UAF41. Frequency • Q product of the UAF42 has been improved, and the useful natural frequency extended by a factor of four to 100kHz. FET-input op amps on the UAF42 provide very low input bias current. The monolithic construction of the UAF42 provides lower cost and improved reliability.

DESIGN PROGRAM

Application Bulletin AB-035 and a computer-aided design program, available from Burr-Brown, make it easy to design and implement many kinds of active filters. The DOS-compatible program guides you through the design process and automatically calculates component values.

Low-pass, high-pass, band-pass and band-reject (notch) filters can be designed. The program supports the three most commonly used all-pole filter types: Butterworth, Chebyshev and Bessel. The less-familiar Inverse Chebyshev is also supported, providing a smooth passband response with ripple in the stop-band.

With each data entry, the program automatically calculates and displays filter performance. This allows a spreadsheet-like "what if" design approach. For example, you can quickly determine, by trial and error, how many poles are required for a desired attenuation in the stopband. Gain/phase plots may be viewed for any response type.

The basic building element of the most commonly used filter types is the second-order section. This section provides a complex-conjugate pair of poles. The natural frequency, ω_n , and Q of the pole pair determines the characteristic response of the section. The low-pass transfer function is

$$\frac{V_O(s)}{V_I(s)} = \frac{A_{LP}\omega_n^2}{s^2 + s \omega_n/Q + \omega_n^2} \quad (1)$$

The high-pass transfer function is

$$\frac{V_{HP}(s)}{V_I(s)} = \frac{A_{HP}s^2}{s^2 + s \omega_n/Q + \omega_n^2} \quad (2)$$

The band-pass transfer function is

$$\frac{V_{BP}(s)}{V_I(s)} = \frac{A_{BP}(\omega_n/Q) s}{s^2 + s \omega_n/Q + \omega_n^2} \quad (3)$$

A band-reject response is obtained by summing the low-pass and high-pass outputs, yielding the transfer function

$$\frac{V_{BR}(s)}{V_I(s)} = \frac{A_{BR}(s^2 + \omega_n^2)}{s^2 + s \omega_n/Q + \omega_n^2} \quad (4)$$

The most commonly used filter types are formed with one or more cascaded second-order sections. Each section is designed for ω_n and Q according to the filter type (Butterworth, Bessel, Chebyshev, etc.) and cutoff frequency. While tabulated data can be found in virtually any filter design text, the design program eliminates this tedious procedure.

Second-order sections may be non-inverting (Figure 1) or inverting (Figure 2). Design equations for these two basic configurations are shown for reference. The design program solves these equations, providing complete results, including component values.

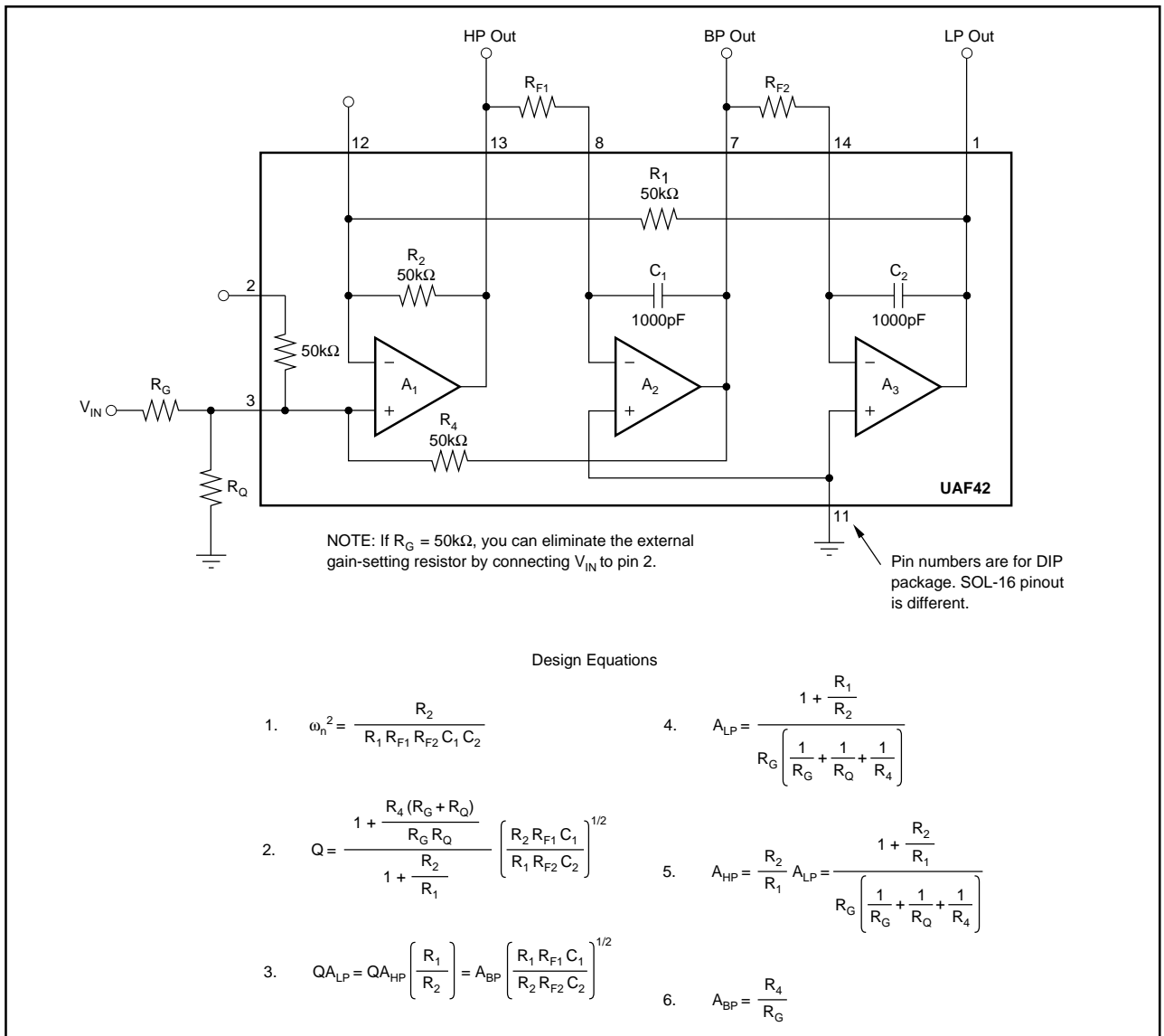
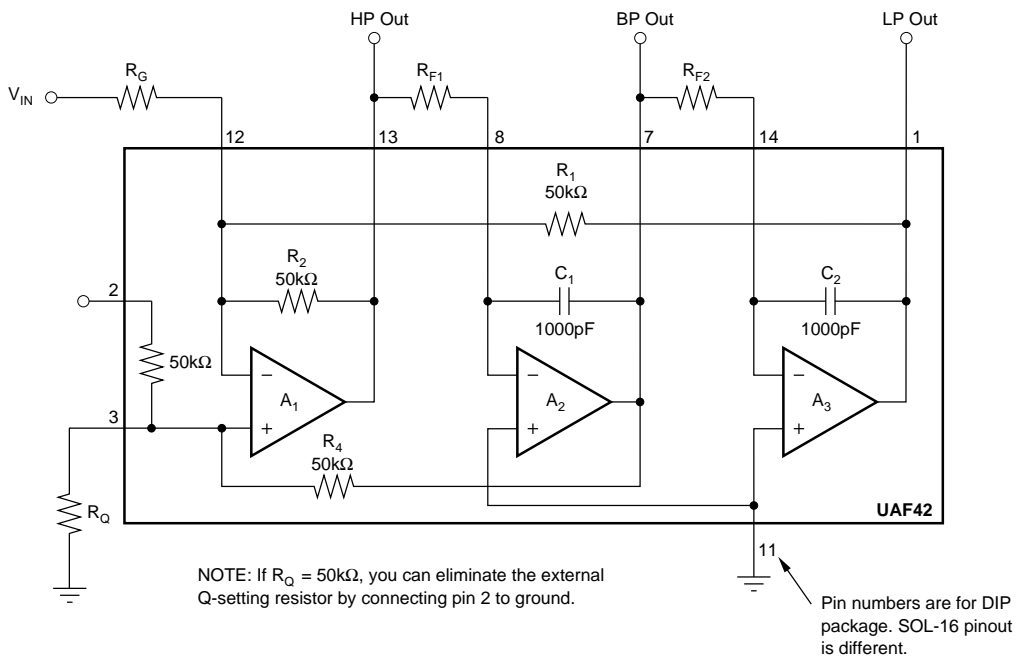

FIGURE 1. Non-Inverting Pole-Pair.



NOTE: If $R_Q = 50k\Omega$, you can eliminate the external Q-setting resistor by connecting pin 2 to ground.

Pin numbers are for DIP package. SOL-16 pinout is different.

Design Equations

$$1. \quad \omega_n^2 = \frac{R_2}{R_1 R_{F1} R_{F2} C_1 C_2}$$

$$4. \quad A_{LP} = \frac{R_1}{R_G}$$

$$2. \quad Q = \left[1 + \frac{R_4}{R_Q} \right] \frac{1}{\left[\frac{1}{R_1} + \frac{1}{R_2} + \frac{1}{R_G} \right]} \left(\frac{R_{F1} C_1}{R_1 R_2 R_{F2} C_2} \right)^{1/2}$$

$$5. \quad A_{HP} = \frac{R_2}{R_1} A_{LP} = \frac{R_2}{R_G}$$

$$3. \quad QA_{LP} = QA_{HP} \left(\frac{R_1}{R_2} \right) = A_{BP} \left(\frac{R_1 R_{F1} C_1}{R_2 R_{F2} C_2} \right)^{1/2}$$

$$6. \quad A_{BP} = \left[1 + \frac{R_4}{R_Q} \right] \frac{1}{R_G \left[\frac{1}{R_1} + \frac{1}{R_2} + \frac{1}{R_G} \right]}$$

FIGURE 2. Inverting Pole-Pair.